

ZOOMLION TELESCOPIC BOOM LIFTS

ZT30J

Comply with CE Standard



HIGHLIGHTS

- ▶ Rough terrain chassis features swing axle function, easy to achieve 45% gradeability
- ▶ Industry's first 30-meter product without bridge extending
- ▶ Smooth & stable boom extension, the telescopic efficiency of the boom is increased by 30% compared with that of the double-cylinder telescopic boom
- ▶ Smooth & stable boom extension technique controls the minimum stable extending speed at 0.015m/s (0.034mph)

FEATURES

Standard Features

Horn
All motion alarm
Proportional control
Self-closing entry gate
Flashing amber beacon
Auto-leveling system
Emergency stop button
Over tilt protection system
Emergency descent system
On-board diagnostic system
Oscillating axle
4.3' LED display
Load sensing system
Swing-out engine tray

Accessories & Options

- ▶ Platform work light
- ▶ Secondary guarding system
- ▶ AC power to platform



ACCESS WITH ZOOMLION GREEN

Phone: 0086(731)-88353680 0086(731)-88250971
E-mail: awm@zoomlion.com

Add: ZOOMLION Wangcheng Industrial Park, Tengfei Road 997, Changsha, Hunan, China
Web: www.en.zoomlion.com

MAIN SPECS OF TELESCOPIC BOOM LIFTS

ZT30J

Comply with CE Standard

Model	ZT30J	
	Imperial	Metric
Size		
Work Height	106ft 7in	32.48m
Platform Height	100ft	30.48m
Horizontal Outreach	64ft 11in	19.78m
A - Stowed Length	40ft 9in	12.43m
B - Stowed Width	8ft 2in	2.49m
C - Stowed Height	9ft 2in	2.80m
D - Platform Length	8ft	2.44m
E - Platform Width	3ft	0.91m
Jib Length	6ft	1.83m
F - Wheelbase	10ft	3.05m
Tread	6ft 11in	2.11m
G - Ground Clearance	1ft 4in	0.40m
Performance		
Platform Capacity (Unrestricted/Restricted)	507/750lb	230/340kg
Drive Speed (Stowed)	3.42mph	5.5km/h
Gradeability	45% (24°)	
Turning Radius (Inside)	12ft	3.66m
Turning Radius (Outside)	22ft 6in	6.86m
Turntable Swing	360° continuous	
Platform Rotation	±90°	
Tail Swing	4ft 10in	1.47m
Jib (Range of Articulation)	130° (-55°~75°)	
Max. Wind Speed	28mph	12.5m/s
Power		
Engine	Cummins QSF2.8	
Engine Power	73hp/2400rpm	54kw/2400rpm
Fuel Tank Capacity	39.6 (us gal)	150L
Control Voltage	12V DC	
Hydraulic Tank Capacity	39.6gal	150L
Drive Mode	4WD	
Steering Mode	Front-wheel	
Tire		
Type	15-625 Foam-filled Tires	
Weight		
Gross	42770lb	19400kg

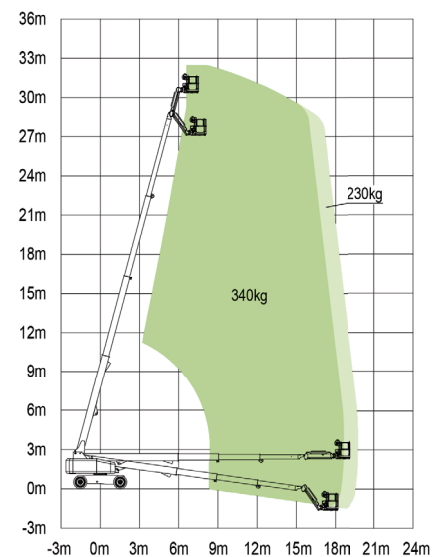
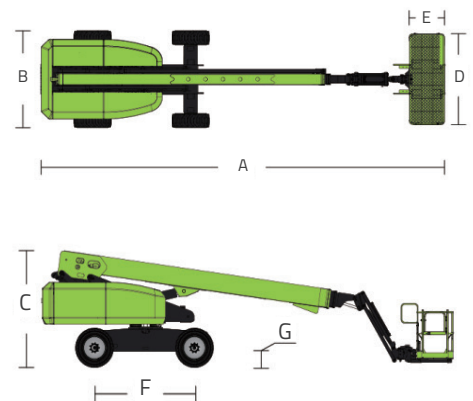

Range of Motion ZT30J